

A design of transmit weights for non-regenerative multiuser MIMO relay system

Cong Li, Yasunori Iwanami

Department of Computer Science and Engineering, Graduate School of Engineering
Nagoya Institute of Technology, Nagoya, 466-8555, Japan

E-mail: chx17515@stn.nitech.ac.jp

Abstract—This paper investigates the cancellation of the interferences among Destination Users (DU's) and the improvement of system rate in the non-regenerative Multiuser Multiple-Input Multiple-Output (MU-MIMO) relay downlink system. A novel design method of transmit weights is proposed to successively eliminate the interference among DU's, each of which is equipped with multiple receive antennas. We firstly study the transmit weights design for the conventional Amplify-and-Forward (AF) relay system where the Relay Station (RS) just retransmits the received signals, then we extend it to the joint design of transmit weights both at the Base Station (BS) and the RS. In the joint design, Singular Value Decomposition (SVD) is used for the first channel link (link between BS and RS), then a user selection algorithm is adopted at the RS to generate the transmit weight of each DU. The channel matrix of system is transformed into a triangular matrix, where the Dirty Paper Coding (DPC) technique is employed to remove the interference among DU's and maintain the achievable rate of system. Simulation results verify the effectiveness of the proposed scheme.

I. INTRODUCTION

Wireless relay communication has attracted considerable interests due to its improvement of the coverage and enhancement of the spectral efficiency of wireless communications [1]-[3]. As a simple and practical technique, the non-regenerative relay scheme just performs as the linear processing for the received signals and then transmits the received signal to the DU's, i.e., AF relay scheme, which does not need any digital signal processing at the RS, but retransmit the received signal to DU's. In the multiuser MIMO relay system, multiple DU's simultaneously communicate with BS through the RS at the same frequency, therefore the multiuser MIMO relay has the advantages to provide higher data rate, system coverage, and to support multiple DU's simultaneously [4]-[8]. Unlike the single user MIMO relay case, the MU-MIMO relay system has not only to consider the cancellation of the interference among DU's but also maintains the high capacity links between the BS and RS. On the other hand, preventing the loss of capacity rate between the RS and DU's caused by user signal separation is also crucial [4],[5],[6],[8]. Two linear processing schemes are proposed to decompose the relay system into the SISO sub-channels [4], where the DPC technique is employed to remove the IUI and at each sub-channel Water Filling (WF) scheme is used to equitably distribute transmit power at the effective channels. However, these schemes are limited in the case of DU's with single receive antennal. A Generalized Water Filling (GWF) theorem is used to optimize the system performance by the theory of convex optimization problems in [6]. Although the authors studied the case in which each DU is equipped with multiple

receive antennas, each receive antenna at DU's still independently detects the received signals, since the DPC technique is employed strictly over the lower triangular matrix. In [6], the transmit user diversity is not considered for the cellular system, where the effective DU's are selected and allocated over communication resource such as time, frequency, etc. However, when user selection is involved, the schemes in [4] and [6] consume the large computational load. Our proposal in this paper not only greatly reduces the calculation load but also uses the user selection algorithm at the RS to ensure the achievable rate of system.

In this paper, we focus on the transmit weight designs for the downlink of multiuser MIMO relay system, where each DU is equipped with multiple antennas. We exploit the DPC technique at the BS and the low complexity user selective scheduling at the RS to ensure the achievable rate of system by optimizing the transmit weight design. The remainder of this paper is organized as follows. Section 2 presents the system model in this paper. In Section 3, we firstly propose the transmit weights design in the conventional AF relay system, and then extend it to the case where some additional intelligence, such as linear signal processing, is needed at the RS. We show the simulation results in Section 4 and the conclusions are given in section 5. We illustrate some of the notations as follows: vectors and matrixes are expressed by bold letters, we use $\text{tr}[\cdot]$, $[\cdot]^T$ and $[\cdot]^H$ as the trace, transpose and conjugate transpose of matrix, respectively.

II. SYSTEM MODEL

Fig.1 illustrates the downlink of multiuser MIMO relay scenario, where the BS is displayed with N_s transmit antennas and communicates with the RS equipped with N_r antennas. A MIMO channel denoted as $\mathbf{H}_1 \in \mathbb{C}^{N_r \times N_s}$ is thus indicated between the BS and RS. The BS transmits the signals processed by the transmit weight $\mathbf{M} \in \mathbb{C}^{N_s \times N_s}$ to the RS. The RS reprocess the received signals with a filter matrix $\mathbf{F} \in \mathbb{C}^{N_r \times N_r}$ and then broadcasts to multiple DU's, where the k-th DU is equipped with $n_d^{(k)}$ ($k=1,2,\dots,N_d$) receive antennas.

The channels between the RS and DU's are denoted as

$$\mathbf{H}_2 = [\mathbf{H}_{2,1}^T \ \dots \ \mathbf{H}_{2,k}^T \ \dots \ \mathbf{H}_{2,N_d}^T]^T \in \mathbb{C}^{N_{2,d} \times N_r} \quad (1)$$

where $N_{2,d} = \sum_{k=1}^{N_d} n_d^{(k)}$ and $\mathbf{H}_{2,k}^T$ is corresponding to the channel of the k-th DU. In this paper, we assume the Channel State Information (CSI) of \mathbf{H}_2 , is available at RS, and the BS generates the transmit signals by using the feedback of \mathbf{H}_1 and \mathbf{H}_2 from RS. In addition, we adopt only two-hop protocol at the RS, and a half-duplex scheme is utilized. The direct links between BS and DU's are neglected due to large loss and severe shadowing effects.

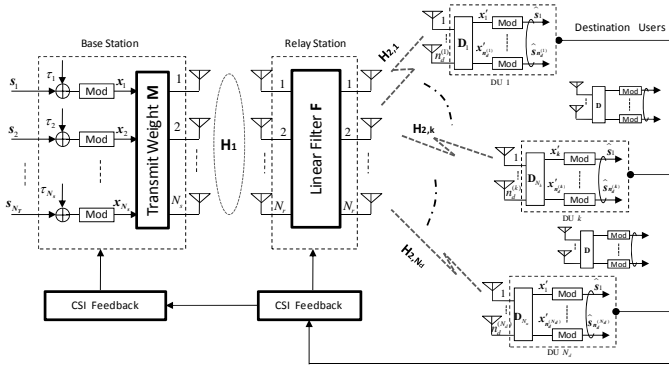

Fig. 1. Multiuser MIMO relay downlink.

In the first time slot, the transmit signal vector for DU's is processed by using the transmit weight \mathbf{M} at BS.

$$\mathbf{M} = [\mathbf{M}_1 \ \mathbf{M}_2 \ \cdots \ \mathbf{M}_{N_d}] \quad (2)$$

The $N_r \times 1$ received signal vector at RS can be expressed as

$$\mathbf{Y}_R = \mathbf{H}_1 \mathbf{M} \mathbf{X} + \mathbf{W}_1 = \mathbf{H}_1 \sum_{j=1}^{N_d} \mathbf{M}_j \mathbf{x}_j + \mathbf{W}_1 \quad (3)$$

where $\mathbf{X} = [\mathbf{x}_1^T \ \cdots \ \mathbf{x}_j \ \cdots \ \mathbf{x}_{N_d}^T]^T \in \mathbb{C}^{N_s \times 1}$ is the transmit signal vector and \mathbf{W}_1 is Additive White Gaussian Noise (AWGN) with zero mean and $\sigma_1^2 \mathbf{I}$ variance. The transmit power constraint at BS can be denoted as

$$\text{tr}(\mathbf{M} \mathbf{M}^H) = P_1 \quad (4)$$

In the second time slot, the RS reprocesses the received signal vector \mathbf{Y}_R with the transmit weight \mathbf{F} and then forwards the data streams to DU's through the MIMO broadcast channels. Thus the $n_d^{(k)} \times 1$ received signal at the k -th DU can be written as

$$\mathbf{y}_k = \mathbf{H}_{2,k} \mathbf{F} \mathbf{H}_1 \sum_{j=1}^{N_d} \mathbf{M}_j \mathbf{x}_j + \mathbf{H}_{2,k} \mathbf{F} \mathbf{W}_1 + \mathbf{w}_{2,k} \quad (5)$$

here, the noise term $\mathbf{w}_{2,k}$ also follows Gaussian distribution, and the transmit power at RS is constrained by

$$\text{tr}(\mathbf{F} \mathbf{H}_1 \mathbf{M} \mathbf{M}^H \mathbf{H}_1^H \mathbf{F}^H) + \text{tr}(\mathbf{F} \mathbf{F}^H) \sigma_1^2 = P_2 \quad (6)$$

III. TRANSMIT WEIGHT DESIGN FOR MULTIUSER MIMO RELAY SYSTEM

1. Transmit weight design for AF relay system

We define the whole channel matrix $\mathbf{H}_W \in \mathbb{C}^{\sum_d N_d \times N_s}$ of relay system in Fig. 1. as follow

$$\mathbf{H}_W = \mathbf{H}_2 \mathbf{F} \mathbf{H}_1 \mathbf{M} = \widehat{\mathbf{H}} \mathbf{M} \quad (7)$$

where $\widehat{\mathbf{H}} \in \mathbb{C}^{N_d \times N_s}$ can be further denoted as

$$\widehat{\mathbf{H}} = [\widehat{\mathbf{H}}_1^T \ \cdots \ \widehat{\mathbf{H}}_k^T \ \cdots \ \widehat{\mathbf{H}}_{N_d}^T]^T \quad (8)$$

here, $\widehat{\mathbf{H}}_k^T$ corresponds to the k -th DU. Firstly, we consider the case of conventional AF relay system, that is, the received signals at RS is simply amplified and retransmitted to the DU's. To remove the interference among DU's, we skillfully design the transmit weight \mathbf{M} at the BS and \mathbf{F} at the RS as follows

$$\mathbf{M} = \widehat{\mathbf{M}} \mathbf{\Gamma}_1^{1/2}, \ \mathbf{F} = \mathbf{I}_{N_r \times N_r} \mathbf{\Gamma}_2^{1/2} \quad (9)$$

where $\mathbf{\Gamma}_1 = \text{diag}(\mathbf{p}_1^1, \dots, \mathbf{p}_1^k, \dots, \mathbf{p}_1^{N_d})$ and $\mathbf{\Gamma}_2 = \text{diag}(\mathbf{p}_2^1, \dots, \mathbf{p}_2^k, \dots, \mathbf{p}_2^{N_d})$ are the power allocation matrix at BS and RS, respectively. The matrix $\widehat{\mathbf{M}} = [\widehat{\mathbf{M}}_1, \dots, \widehat{\mathbf{M}}_k, \dots, \widehat{\mathbf{M}}_{N_d}]$ ensures \mathbf{H}_W can be transformed into parallel single user MIMO relay

channels. For the k -th DU, let define the previous $k-1$ DUs' combined channel matrix $\widetilde{\mathbf{H}}_k$ and its corresponding singular value decomposition (SVD) as

$$\widetilde{\mathbf{H}}_k = \begin{bmatrix} \widehat{\mathbf{H}}_1 \\ \vdots \\ \widehat{\mathbf{H}}_{k-1} \end{bmatrix} = \mathbf{U}_k \mathbf{A}_k [\mathbf{V}_k^1 \ \mathbf{V}_k^0]^H \quad (10)$$

where \mathbf{V}_k^0 holds the $N_s - \sum_{i=1}^{k-1} n_i^{(i)}$ right singular vectors and forms an orthogonal basis for the null space of $\widetilde{\mathbf{H}}_k$, so its columns are, thus, candidate the transmit weights of \mathbf{M}_k ($k=2, \dots, N_d$) of the k -th MD. For the first DU, $\widehat{\mathbf{M}}_1$ is achieved from the eigenvectors which ensure the maximum transmit gain. In addition, in equation (10), we can also use the QR decomposition of $\mathbf{I} - \widetilde{\mathbf{H}}_k^H \widetilde{\mathbf{H}}_k$ to obtain the null space of matrix $\widetilde{\mathbf{H}}_k$ to reduce the computational complexity [9]. Thus, the whole channel matrix of system in (7) is expressed as

$$\mathbf{H}_W = \begin{bmatrix} \widehat{\mathbf{H}}_1 \mathbf{M}_1 & \widehat{\mathbf{H}}_1 \mathbf{M}_2 & \cdots & \widehat{\mathbf{H}}_1 \mathbf{M}_{N_d} \\ 0 & \widehat{\mathbf{H}}_2 \mathbf{M}_2 & \cdots & \widehat{\mathbf{H}}_2 \mathbf{M}_{N_d} \\ \vdots & \vdots & \ddots & \vdots \\ 0 & 0 & \cdots & \widehat{\mathbf{H}}_{N_d} \mathbf{M}_{N_d} \end{bmatrix} \quad (11)$$

Since the DPC technique can not be employed on the block triangular matrices directly, we carefully design the decoder matrix \mathbf{D} at DU's side as

$$\mathbf{D} = \text{diag}(\mathbf{G}_1 \mathbf{h}'_1, \dots, \mathbf{G}_k \mathbf{h}'_k, \dots, \mathbf{G}_{N_d} \mathbf{h}'_{N_d}) \quad (12)$$

where $\mathbf{h}'_{pq} = \widehat{\mathbf{H}}_p \mathbf{M}_q$ ($p, q=1, 2, \dots, N_d$) and $\mathbf{G}_k = \text{diag}^{-1}(\mathbf{R}_k)$, and the triangular matrix \mathbf{R}_k is obtained by the Cholesky decomposition of $\mathbf{R}_k^H \mathbf{R}_k = \text{chol}(\mathbf{h}'_k \mathbf{h}'_k^H)$.

Therefore, the effective channel matrix \mathbf{H}_E of system can be expressed as follows

$$\mathbf{H}_E = \mathbf{D} \mathbf{H}_2 \mathbf{F} \mathbf{H}_1 \mathbf{M} = \mathbf{D} \mathbf{H}_W = \mathbf{D}' \mathbf{R}' \quad (13)$$

$$\mathbf{D}' = \text{diag}[\mathbf{G}_1 \mathbf{R}_1^H \ \cdots \ \mathbf{G}_k \mathbf{R}_k^H \ \cdots \ \mathbf{G}_{N_d} \mathbf{R}_{N_d}^H]$$

From the triangular matrix \mathbf{R}' in (13), the transmit signal vector is generated to remove the interference among DU's by employing the DPC at BS.

Consequently, The effective SINR for the i -th data stream at the k -th DU is

$$\text{SINR}_{AF} = \frac{p_{1,i}^k p_{2,i}^k |r_{i,i}^{(k)}|^2}{\|\mathbf{H}_{2,k} \mathbf{F}\|^2 \sigma_1^2 / n_d^{(k)} + \sigma_2^2} \quad (14)$$

The achievable rate of relay system can be expressed as

$$C_{AF} = \frac{1}{2} \max \left[\sum_{k=1}^{N_d} \sum_{i=1}^{n_d^{(k)}} \log_2(1 + \text{SINR}) \right]$$

$$= \frac{1}{2} \max_{\mathbf{p}_{1,i}^k, \mathbf{p}_{2,i}^k} \left[\sum_{k=1}^{N_d} \sum_{i=1}^{n_d^{(k)}} \log_2 \left(1 + \frac{p_{1,i}^k |r_{i,i}^{(k)}|^2}{\|\mathbf{H}_{2,k} \mathbf{F}\|^2 \sigma_1^2 / n_d^{(k)} + \sigma_2^2} \right) \right]$$

subject to

$$\text{tr}(\mathbf{F} \mathbf{H}_1 \mathbf{M} \mathbf{M}^H \mathbf{H}_1^H \mathbf{F}^H) + \text{tr}(\mathbf{F} \mathbf{F}^H) \sigma_1^2 \leq P_2,$$

$$\sum_{i=1}^{N_d} p_{1,i} \leq P_1, p_{1,i} \geq 0, p_{1,i} \in \mathbf{p}_1 \quad (15)$$

where $r_{i,i}^{(k)}$ is the diagonal element of \mathbf{R}' .

2. Joint weight (JD) design at both BS and RS

To obtain the transmit user diversity but not lead to great computation load, we carefully design the transmit weight at

the RS.

A) Cancellation of interference

Firstly, we apply SVD to the matrix the first link \mathbf{H}_1 .

$$\mathbf{H}_1 = \mathbf{U}_1 \mathbf{A}_1 \mathbf{V}_1^H \quad (16)$$

where $\mathbf{U}_1 \in \mathbb{C}^{N_r \times N_r}$ and $\mathbf{V}_1 \in \mathbb{C}^{N_s \times N_s}$ are unitary matrix, and $\mathbf{A}_1 = \text{diag}(\lambda_1^1, \dots, \lambda_1^k, \dots, \lambda_1^{N_d})$; $\lambda_{1,i}^k \in \lambda_1^k$ is the diagonal matrix composed of the singular value of \mathbf{H}_1 . We design the transmit weight \mathbf{M} at the BS and \mathbf{F} at the RS as follows

$$\mathbf{M} = \mathbf{V}_1 \mathbf{I}_1^{1/2}, \quad \mathbf{F} = \mathbf{F}_2 \mathbf{F}_1 \quad (17)$$

Here, $\mathbf{F}_1 = \mathbf{U}_1^H \mathbf{I}_1^{1/2}$ is set for the first link and \mathbf{F}_2 is for the second link to cancel the interference among DU's. Similarly, we construct the previous k-1 DUs' related matrix as

$$\tilde{\mathbf{H}}_{2,k} = \begin{bmatrix} \mathbf{H}_{2,1} \\ \vdots \\ \mathbf{H}_{2,k-1} \end{bmatrix} = \mathbf{U}_{2,k} \mathbf{A}_{2,k} [\mathbf{V}_{2,k}^1 \quad \mathbf{V}_{2,k}^0]^H \quad (18)$$

The columns of $\mathbf{V}_{2,k}^0$ constitute the transmit weight $\mathbf{F}_{2,k}$ of the user k ($k=2, \dots, N_d$) and $\mathbf{F}_{2,1}$ is composed of the eigenvectors of $\mathbf{H}_{2,1}$. Thus, the whole channel matrix of system is expressed as

$$\mathbf{H}_W = \begin{bmatrix} \mathbf{H}_{2,1} \mathbf{F}_{2,1} & \mathbf{H}_{2,1} \mathbf{F}_{2,2} & \cdots & \mathbf{H}_{2,1} \mathbf{F}_{2,N_d} \\ 0 & \mathbf{H}_{2,2} \mathbf{F}_{2,2} & \cdots & \mathbf{H}_{2,2} \mathbf{F}_{2,N_d} \\ \vdots & \vdots & \ddots & \vdots \\ 0 & 0 & \cdots & \mathbf{H}_{2,N_d} \mathbf{F}_{2,N_d} \end{bmatrix} \mathbf{I}_2^{1/2} \mathbf{A}_1 \mathbf{I}_1^{1/2} \quad (19)$$

To transform the above \mathbf{H}_W into a triangular matrix, the decoder matrix \mathbf{D} at the DU's side is designed as

$$\mathbf{D} = \text{diag}[\mathbf{G}_1 \mathbf{h}'_1 \cdots \mathbf{G}_k \mathbf{h}'_k \cdots \mathbf{G}_{N_d} \mathbf{h}'_{N_d}] \quad (20)$$

Here, $\mathbf{h}'_{pq} = \mathbf{H}_{2,p} \mathbf{F}_{2,q}$, and $\mathbf{G}_k = \text{diag}^{-1}(\mathbf{R}_k) \mathbf{R}_k^{H^{-1}}$, \mathbf{R}_k is achieved by the Cholesky decomposition of $\mathbf{R}_k^H \mathbf{R}_k = \text{chol}(\mathbf{h}'_k \mathbf{h}'_k^H)$.

Consequently, the effective channel matrix \mathbf{H}_E of system is denoted as follows

$$\mathbf{H}_E = \mathbf{D} \mathbf{H}_2 \mathbf{F} \mathbf{H}_1 \mathbf{M} = \mathbf{D} \mathbf{H}_W = \mathbf{D}' \mathbf{R}' \quad (21)$$

$$\mathbf{R}' = \begin{bmatrix} \mathbf{R}_1 \mathbf{I}_{2,1}^{1/2} \mathbf{A}_{1,1} \mathbf{I}_{1,1}^{1/2} & \cdots & (\mathbf{R}_1^H)^{-1} \mathbf{h}'_1 \mathbf{h}'_{N_d} \\ \mathbf{0} & \ddots & \vdots \\ \mathbf{0} & \mathbf{0} & \mathbf{R}_{N_d} \mathbf{I}_{2,N_d}^{1/2} \mathbf{A}_{1,N_d} \mathbf{I}_{1,N_d}^{1/2} \end{bmatrix}$$

From the generated triangular matrix \mathbf{R}' in (21), the BS generates transmit signal, where DPC technique is used to pre-subtract the interference among DU's.

B) User selection algorithm at RS

It is noticed that the successive interference cancellation strategy can achieve optimal user order which ensures the achievable rate of system. However, the cellular network communication is usually concerned with the effective user selection, in which case the design method in the conventional AF relay system has no transmit user diversity and consumes a great deal of calculation load. In this section, we propose a low complexity of user selection at the RS. We consider that the uniform transmit power is allocated to each sub channels at the first links \mathbf{H}_1 . For the second links, we introduce the greedy algorithm to select DU's and the Water Filling (WF) method is employed to allocate transmit power at the RS. Let $U = \{1, \dots, k, \dots, K\}$ denotes the congregation of all DU's. N_d is

the number of effective users, with whom the BS communicates at some time slot.

At high SINR, the following relationship of achievable rate for the k-th DU is valid and detailed in Appendix 1.

$$C_{JD}^k \langle p_{2,i}^k, r_{i,i}^k \rangle \approx C_{JD}^k \langle p_{2,i}^k, \lambda_{2,i}^k \rangle \quad (22)$$

where $\lambda_{2,i}^k$ ($i=1, \dots, n_d^k$) is the eigenvalue of $\mathbf{h}'_{kk} \mathbf{h}'_{kk}^H$.

For two vectors $\mathbf{m}, \mathbf{n} \in \mathbb{R}$ with order of components $m_1 \geq m_2 \geq \dots \geq m_L \geq 0$ and $n_1 \geq n_2 \geq \dots \geq n_L \geq 0$, we say that $\mathbf{m} > \mathbf{n}$ and express

$$\mathbf{m} > \mathbf{n} \text{ if } m_l \geq n_l, \forall l=1, 2, \dots, L \quad (23)$$

Therefore, the vector composed of diagonal entries of the Hermite matrix $\mathbf{h}'_{kk} \mathbf{h}'_{kk}^H$ corresponding to the k-th DU is majorized by the vector of the eigenvalues of it [10].

$$\boldsymbol{\lambda}(\mathbf{h}'_{kk} \mathbf{h}'_{kk}^H) \succeq [(\mathbf{h}'_{kk} \mathbf{h}'_{kk}^H)_{ii}]_{i=1}^{n_d^k} \quad (24)$$

In addition, under the same constraint of transmit power, the achievable rate of the k-th DU is increasing function of the effective channel gain. From (22), (23) and (24), we obtain the following relational expression

$$C_{JD}^k \langle p_{2,i}^k, r_{i,i}^k \rangle \approx C_{JD}^k \langle p_{2,i}^k, \lambda_{2,i}^k \rangle \geq C_{JD}^k \langle p_{2,i}^j, (\mathbf{h}'_{kk} \mathbf{h}'_{kk}^H)_{ii} \rangle \quad (25)$$

which presents the lower bound of rate of system, thus, we search for the upper bound value of $[(\mathbf{h}'_{kk} \mathbf{h}'_{kk}^H)_{ii}]_{i=1}^{n_d^k}$ to ensure the achievable rate of system. The proposed user selection algorithm is shown in Table 1.

Table 1. User Selection algorithms at RS.

Step 1: Initialization
Let $U = \{1, 2, \dots, K\}$, $\Theta = \emptyset$;
Define $\mathbf{H}_{2,U} = [\mathbf{H}_1^T \quad \mathbf{H}_2^T, \dots, \mathbf{H}_K^T]^T$;
Step 2: User 1
For $i = 1: K$
$\mathbf{A}_i = \text{diag}(\mathbf{H}_{2,i}^H \mathbf{H}_{2,i})$;
End
$k = \max(\mathbf{A}_k)$, $k = \max(\mathbf{A}_k)$, $k \in U$;
$\mathbf{H}_{2,k} = \mathbf{U}_{2,k} \mathbf{A}_{2,k} [\mathbf{V}_{2,k}^1 \quad \mathbf{V}_{2,k}^0]^H$, $\mathbf{F}_{2,k} \in \mathbf{V}_{2,k}^1$;
$\Theta = \Theta \cup k$;
$U = U \setminus k$;
Step 3: User i
For $i = 2: N_d$
$\hat{\mathbf{H}}_{2,i} = \mathbf{H}_{2,\Theta}$, where $\mathbf{H}_{2,\Theta} = [\mathbf{H}_{2,\Theta}^T, \dots, \mathbf{H}_{2,\Theta}^T, \dots]^T$, $\Theta_i \in \Theta$;
$\hat{\mathbf{H}}_{2,i} = \mathbf{U}_{2,i} \mathbf{A}_{2,i} [\mathbf{V}_{2,i}^1 \quad \mathbf{V}_{2,i}^0]^H$, $\mathbf{F}_i \in \mathbf{V}_{2,i}^1$;
$\mathbf{A}_k = \text{diag}(\mathbf{F}_i^H \mathbf{H}_{2,k}^H \mathbf{H}_{2,k} \mathbf{F}_i)$, $k \in U$; $k = \max(\mathbf{A}_k)$, $k \in U$;
$\Theta = \Theta \cup k$;
$U = U \setminus k$;
End
$\mathbf{H}_2 = \mathbf{H}_{2,\Theta}$

In the process of user selection, we obtain the optimal user order by comparing the vector composed of the diagonal entries of $[(\mathbf{h}'_{kk} \mathbf{h}'_{kk}^H)_{ii}]_{i=1}^{n_d^k}$, thus, the great computational load caused by SVD can be avoided.

Consequently, we give the effective SINR for the i -th data stream at the k -th DU as

$$SINR_{JD} = \frac{p_{1,i}^k p_{2,i}^k |\lambda_{1,i}^k|^2 |r_{i,i}^k|^2}{p_{2,i}^k \sigma_1^2 |r_{i,i}^k|^2 + \sigma_2^2} \quad (26)$$

The achievable rate of relay system can be expressed as

$$C_{JD} = \frac{1}{2} \max \left[\sum_{k=1}^{N_d} \sum_{i=1}^{n_d^k} \log_2(1 + SINR) \right]$$

$$= \frac{1}{2} \max_{\{p_{1,i}^k, p_{2,i}^k\}} \left[\sum_{k=1}^{N_d} \sum_{i=1}^{n_d^k} \log_2 \left(1 + \frac{p_{1,i}^k p_{2,i}^k |\lambda_{1,i}^k|^2 |r_{i,i}^k|^2}{p_{2,i}^k \sigma_1^2 |r_{i,i}^k|^2 + \sigma_2^2} \right) \right]$$

subject to

$$\begin{aligned} & \text{tr}(\mathbf{F}\mathbf{H}_1\mathbf{H}_1^H\mathbf{F}^H) + \text{tr}(\mathbf{F}\mathbf{F}^H)\sigma_1^2 \leq P_2 \\ & \sum_{k=1}^{N_d} \sum_{i=1}^{n_d^k} p_{1,i}^k \leq P_1, p_{1,i}^k \geq 0, \sum_{i=1}^{n_d^k} p_{1,i}^k = p_1^k, p_{1,i}^k \in \mathcal{P}_1^k \end{aligned} \quad (27)$$

The optimization in (15) and (27) can be transformed into a conventional geometric program [11], but the iterative algorithm leads to large computation.

IV. SIMULATION RESULTS

In this section, computer simulation results are presented to evaluate the performance of proposed transmit scheme. Without loss of the generality, we assume RS is located in middle of BS and DU's and the channel model is flat Rayleigh (i.i.d.) fading.

We consider the case of $4 \times 4 \times [2,2]$ ($N_s=4; N_r=4; n_d^{(k)}=2, k=1,2$) contributing channels in MU-MIMO relay system, where the average achievable rate of system is determined for 1000 realizations of \mathbf{H}_1 and \mathbf{H}_2 . Fig. 2 Shows that the joint weight design method obtains the better rate performance compared with that in the AF relay case. This is because joint weight design method get the transmit user diversity at the RS. In addition, to evaluate the performance of the proposal, we give the theoretical rate upper bound $C(\mathbf{H}_1)/2$ of system, it is derived in Appendix 2.

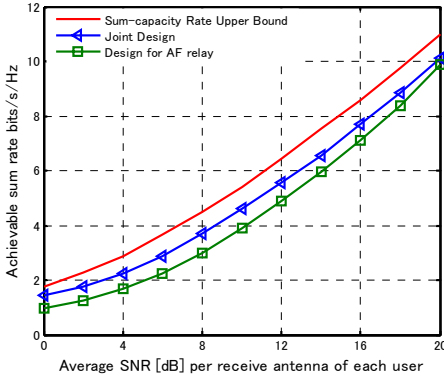

Fig. 2. Achievable rate performance of system with the proposed transmit weight design ($K=2, N_d=2$).

Next we consider the case of antenna correlation, where ρ_r and ρ_d denote the correlation coefficient between antennas at RS and DU's, respectively.

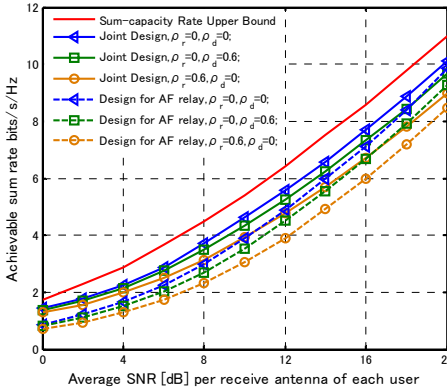

Fig. 3. System rate performance with antenna correlation at RS and DU's ($K=2, N_d=2$).

Simulation results in Fig. 3. show that the correlation at RS or DU's deteriorates the rate performance. On the same condition of correlation coefficient, performance with joint weight design, having the diversity at RS, gets the advantage over that in the AF relay case. It is also noticed that the correlation at RS more easily affect the performance of system, i.e., at the rate of 8bits/s/Hz, and $\rho_d=0.6$, thus, deteriorates by about 2 dB compared with the case of absence of correlation, while the case of correlation at DU only deteriorates by about 1 dB.

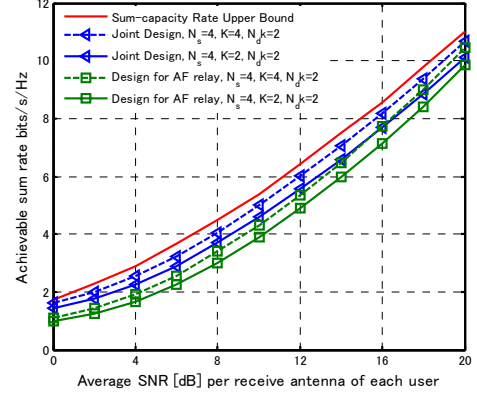

Fig. 4. System rate performance with transmit user diversity ($K=2, 4; N_d=2$).

For the cellular communication, to ensure the system rate, we often select the effective user at some time slot. As shown in Fig. 4, we can obtain the better rate performance when the effective user selection scheme is employed, i.e., $N_d=2$ is selected from the users of $K=4$.

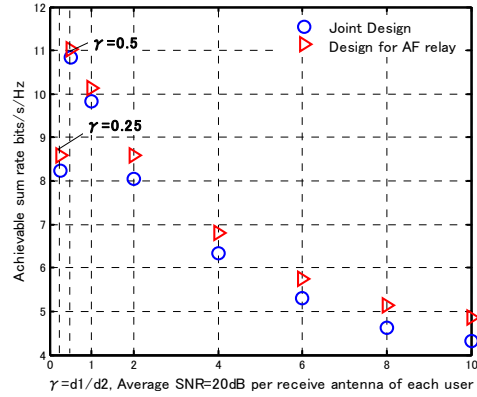

Fig. 5. Achievable rate performance with different locations for free-space propagation.

Next we study the effect of location of RS on the whole system rate performance. Let coefficient γ be the ratio of the distance d_1 (between the BS and RS) and the distance d_2 (between the RS and the DU's). We assume the flat Rayleigh fading \mathbf{H}_1 and \mathbf{H}_2 are compatible with the free space, that is, the gain the channel is inversely proportion to the square of distance between the transmitter and receiver. Fig. 5. shows the rate performance at different values of γ . It is noticed that the rate of system reaches the maximum at some γ in the interval of $(0.25, 0.5]$. Since the maximum value is up to many factor, such as, power allocation, etc. and beyond the range of this paper, we will not study in detail. In addition, as the RS

moves toward to the DU's (such as, from $\gamma=1$ to $\gamma=10$) the rate performance of the whole system gradually degrades because of the amplification of the noise from fist link.

V. CONCLUSIONS

In this paper, we studied the transmit weight design for the downlink of multiuser MIMO relay system, where each DU is equipped with multiple receive antennas. A novel transmit weight design is implemented for the cancellation of interferences among DU's. Firstly, we focus on the weight design for the conventional AF relay case, but despite of its low computational load, it cannot obtain the transmit user diversity at RS. Therefore we next proposed the joint weight design method, where the user selection algorithm is employed at the RS to obtain the transmit user diversity. From computer simulation results we have verified that the joint weight design method obtains the better rate performance compared with the design in the AF relay case. The DPC transmit technique is used to ensure the achievable rate of the whole system.

VI. APPENDIX

1. Derivation of achievable rate of the proposed scheme

For the user k , we define the relationship as follows

$$\mathbf{R}_k = \text{chol}(\mathbf{h}'_{kk} \mathbf{h}''_{kk}), \quad \prod_{i=1}^{n_d^k} \lambda_{2,i}^k = \det(\mathbf{H}_{2,k} \mathbf{H}_{2,k}^H) = \prod_{i=1}^{n_d^k} r_{i,i}^k \quad (28)$$

Here, the arithmetic means of $1/\lambda_{1,i}^k r_{i,i}^k$ and $1/\lambda_{1,i}^k \lambda_{2,i}^k$ are expressed as

$$\Delta_a = \frac{1}{n_d^k} \sum_{i=1}^{n_d^k} \frac{1}{|\lambda_{1,i}^k|^2 |r_{i,i}^k|^2}, \quad \Delta'_a = \frac{1}{n_d^k} \sum_{i=1}^{n_d^k} \frac{1}{|\lambda_{1,i}^k|^2 |r_{i,i}^k|^2} \quad (29)$$

and the geometric mean

$$\Delta_g = \left(\prod_{k=1}^{N_r} 1/|\lambda_{1,i}^k|^2 |r_{i,i}^k|^2 \right)^{1/n_d^k} = \left(\prod_{i=1}^{n_d^k} 1/|\lambda_{1,i}^k|^2 |r_{i,i}^k|^2 \right)^{1/n_d^k} \quad (30)$$

The achievable rate of user k with water filling can be denoted as

$$C_{JD}^k \approx \frac{1}{2} \max \left[\sum_{i=1}^{n_d^k} \log_2(\mu p_s |\lambda_{1,i}^k|^2 |r_{i,i}^k|^2 / \sigma^2) \right] \quad (31)$$

where $p_s = P_1 / N_s$, and μ solves

$$\sum_{i=1}^{n_d^k} [\mu - \sigma^2 / p_s |\lambda_{1,i}^k|^2 |r_{i,i}^k|^2]_+ = p_2^k, \quad \sum_{k=1}^{N_d} p_2^k = P_2 \quad (32)$$

here, $\sigma^2 = p_{2,i}^k |r_{i,i}^k|^2 \sigma^2 + \sigma^2$. Then we find μ to satisfy (32) with $p_2^k < \infty$. In (32) we assume $\mu > \sigma^2 / p_s |\lambda_{1,i}^k|^2 |r_{i,i}^k|^2$ and it becomes

$$\sum_{i=1}^{n_d^k} \mu - \sum_{i=1}^{n_d^k} \sigma^2 / p_s |\lambda_{1,i}^k|^2 |r_{i,i}^k|^2 = p_2^k \Rightarrow \sum_{i=1}^{n_d^k} \mu = p_2^k + \sum_{i=1}^{n_d^k} \sigma^2 / p_s |\lambda_{1,i}^k|^2 |r_{i,i}^k|^2 \quad (33)$$

let $\mu_0 = p_2^k / n_d^k + \Delta_a$, we obtain

$$\sum_{i=1}^{n_d^k} \mu_0 = \sum_{i=1}^{n_d^k} \left(\frac{p_2^k}{n_d^k} + \Delta_a \right) = p_2^k + \sum_{i=1}^{n_d^k} \Delta_a = p_2^k + \sum_{i=1}^{n_d^k} 1/|\lambda_{1,i}^k|^2 |r_{i,i}^k|^2 \quad (34)$$

Formula (34) proves the existence of μ_0 . So for all $p_2^k < p_2^k$, (31) can be expressed as

$$\begin{aligned} C_{JD}^k &\approx \frac{1}{2} \sum_{i=1}^{n_d^k} \left[\log_2 \mu p_s |\lambda_{1,i}^k|^2 |r_{i,i}^k|^2 / \sigma^2 \right]_+ \\ &= \frac{1}{2} \sum_{i=1}^{n_d^k} \left\{ \log_2 \left(p_2^k / n_d^k + \Delta_a \right) p_s |\lambda_{1,i}^k|^2 |r_{i,i}^k|^2 / \sigma^2 \right\}_+ \\ &= \frac{1}{2} \left\{ \log_2 \left(p_2^k / n_d^k + \Delta_a \right) p_s \prod_{k=1}^{n_d^k} |\lambda_{1,i}^k|^2 |r_{i,i}^k|^2 / \sigma^{2n_d^k} \right\}_+ \\ &= \frac{1}{2} \left\{ \log_2 \left[\left(p_2^k / n_d^k + \Delta_a \right) p_s / \Delta_g \sigma^2 \right] \right\}_+ \end{aligned}$$

$$= \frac{n_d^k}{2} \left\{ \log_2 \left[\left(p_2^k / n_d^k + \Delta_a \right) p_s / \Delta_g \sigma^2 \right] \right\}_+ \quad (35)$$

In the high SINR, we have

$$\begin{aligned} C_{JD}^k &\stackrel{(a)}{\approx} \lim_{p_2^k \rightarrow \infty} \frac{1}{2} \max \left[\sum_{i=1}^{n_d^k} \log_2(\mu p_s |\lambda_{1,i}^k|^2 |r_{i,i}^k|^2 / \sigma^2) \right] \\ &= \frac{n_d^k}{2} \lim_{p_2^k \rightarrow \infty} \left\{ \log_2 \left[\left(p_2^k / n_d^k + \Delta_a \right) p_s / \Delta_g \sigma^2 \right] \right\}_+ \\ &\approx \frac{n_d^k}{2} \left\{ \log_2 \left[\left(p_2^k / n_d^k \right) p_s / \Delta_g \sigma^2 \right] \right\}_+ \\ &\stackrel{(b)}{\approx} \frac{n_d^k}{2} \lim_{p_2^k \rightarrow \infty} \left\{ \log_2 \left[\left(p_2^k / n_d^k + \Delta'_a \right) p_s / \Delta_g \sigma^2 \right] \right\}_+ \\ &\approx \lim_{p_2^k \rightarrow \infty} \frac{1}{2} \max \left[\sum_{i=1}^{n_d^k} \log_2(\mu p_s |\lambda_{1,i}^k|^2 |r_{i,i}^k|^2 / \sigma^2) \right] \end{aligned} \quad (36)$$

It is noticed that C_{JD}^k does not depend on the terms Δ_a and Δ'_a . Therefore, from the (a) and (b) of (36), the relationship in (22) can be derived.

2. Derivation of upper bound of rate for the whole system

It is known that Y_d depends on Y_r but conditional independents on X , we have

$$X \rightarrow Y_r \rightarrow Y_d \quad (37)$$

From the above Markov chain, we obtain the following relationship [4]

$$I(X; Y_d) \leq I(X; Y_r) \quad (38)$$

So the upper bound of rate of the system in this paper can be expressed as

$$R_{\text{upper-bound}} = \frac{1}{2} \max [I(X; Y_d)] \leq \frac{1}{2} \max [I(X; Y_r)] = \frac{1}{2} C(\mathbf{H}_1) \quad (39)$$

where 1/2 means two time slots are implemented.

ACKNOWLEDGEMENT

This study has been supported by the Scientific Research Grant-in-aid of Japan No. 21560396, Japan Science and Technology Agency (JST) and Sharp Corporation. The authors also acknowledge the helps from Iwanami-Okamoto laboratory members.

REFERENCE

- [1] R. Pabst, B. H. Walke, "Relay-based deployment concepts for wireless and mobile broadband radio," IEEE Communications Magazine, vol. 42, Issue9, pp. 80-89, Sep.2004.
- [2] G. Kramer, M. Gastpar, and P. Gupta, "Cooperative Strategies and Capacity Theorems for Relay Networks," IEEE Transaction on Information Theory, Vol. 51, NO. 9, Sep.2005.
- [3] X. Tang and Y. Hua, "Optimal design of non-regenerative MIMO wireless relay," IEEE Transactions on Wireless Communications, vol. 6, pp. 1398-1407, Apr.2007.
- [4] C. Chae, T. Tang, R. Heath, and S. Cho, "MIMO relaying with linear processing for multiuser transmission in fixed relay networks," IEEE Transaction Signal Processing, vol. 56, no. 2, pp. 727-738, Feb. 2008.
- [5] L. Gen, W. Ying, W. Tong and H. Jing, "Joint Linear Filter Design in Multi-User Non-regenerative MIMO-Relay Systems," IEEE ICC, Jun. 2009.
- [6] Heliot, F., Hoshyar, R., Tafazolli, R., "Power allocation for the downlink of non-regenerative cooperative multi-user MIMO communication system," IEEE PIMRC, pp.905, Sept. 2010.
- [7] Y. Yuan, H. Yingbo, "Power Allocation for a MIMO Relay System with Multiple-Antenna Users," IEEE Transactions on Signal Processing, Vol. 58, No. 5, May 2010
- [8] Xu, W., Dong, X., Lu, W.S., "Joint Optimization for Source and Relay Precoding under Multiuser MIMO Downlink Channels," ICC 2010, pp.1-5, May, 2010.
- [9] Caire, G., Shamai, S., "On the Achievable Throughput of a Multi-antenna Gaussian Broadcast Channel," IEEE TRANSACTIONS ON INFORMATION THEORY, VOL. 49, NO. 7, pp. 1691 - 1706, Jul. 2003.
- [10] E. Jorswieck and H. Boche, "Majorization and matrix-monotone functions in wireless communication," Found. Trends Commun. Inf. Theory, vol. 3, no.6, pp. 563-584, 2007.
- [11] Stephen Boyd, Lieven Vandenberghe, "Convex Optimization," Cambridge University Press, pp. 160-167, 2004.